

Features

TrueAlarm addressable CO sensor base with 520 Hz sounder provides CO toxic gas monitoring and enhanced fire detection

- CO sensor bases with 520 Hz tone require a TrueAlarm photoelectric, photo/heat or heat sensor (ordered separately)
- CO sensor bases with 520 Hz tone are multi-point devices, use a single IDNet address, and receive communications and sensor power from the IDNet channel (the sounder base requires separate 24 VDC system power or NAC connection)
- IDNet circuit allows the sounder to be supervised and coded by compatible NACs, allowing synchronized temporal, march time, or other channel coding.
- For use with 4007ES; and 4010ES or 4100ES fire alarm control panels with software revision 2.01.02 or higher
- For use with 4100U fire alarm control panels with software revision 12.05 or higher
- Listed to UL 268, UL 464, UL 2075, ULC-S529 and CSA 6.19-01
- Two types of CO influenced operation are available; UL 2075 CO (OSHA) level monitoring for ventilation control; and multi-criteria fire sensor analysis combining optical and CO gas monitoring information

CO sensor base with photoelectric or photo/heat sensor operation

- Independent sensor operation or selectable multi-sensor modes for false alarm reduction or faster detection
- CO and photoelectric sensors can be analyzed together to reject non-fire conditions that can trigger false alarms (steam, dust, etc)
- An increased sensitivity algorithm analyzes CO and photoelectric sensor information to allow the presence of CO to increase photoelectric sensitivity for high value locations (museums, electrical equipment rooms, etc)

520 Hz Sounder base operation

- Low frequency sound output (520Hz at 85 dBA)
- The base can supervise the sounder drive circuit when an AUX 24V power line is used for sounder power. Alternatively, base supervision can be disabled if a supervised NAC is needed to power the sounder for coded outputs.
- When connected to a panel NAC through the 4905-9835 Temporal Code Module, the sounder base can provide temporal code 3 (TC3) for fire, or temporal code 4 (TC4) for toxic carbon monoxide alarms

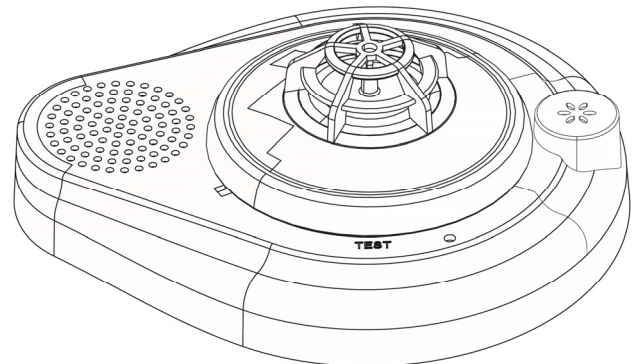

TrueAlarm CO Sensor Base with 520 hz sounder
4098-9773 with CO sensor and Heat Sensor installed

Features (Continued)

- 4905-9835 module may also be used to code other (non-fire) dedicated carbon monoxide notification appliances (refer to data sheet S4905-0006)
- Sounder can be manually activated from the panel

Panel operation summary:

- CO sensor data is stored and analyzed at the panel; a new CO Service Report provides easy information access (see sample on page 3)
- 4007ES, 4010ES, and 4100ES panels provide 10 year end of life status indication with CO sensor expiration notices occurring within 12 months and within 6 months, allowing service replacement planning
- 4100U panels provide 5 year end of life status indication with the 12 and 6 month replacement notices
- Analog sensor information is digitally transmitted to the host control panel via IDNet communications for processing to evaluate and track status
- Carbon monoxide concentration in ppm (parts per million) is available for viewing from the panel user interface
- For OSHA compliant CO gas sensing, CO condition level may be programmed by concentration (must be above 30 ppm)

General features:

- Ceiling mount operation
- Operation of a CO sensor base with heat sensor provides dual independent sensor operation
- CO test mode allows functional testing of each sensor technology including the CO sensor
- Optional accessories include remote alarm LED and mounting adapter plate
- Designed for EMI compatibility
- Magnetic test feature
- CO sensor element is easily replaced when end of service life is reached. Access to CO sensor replacement cartridge (CORC, 4098-9747) requires removal of interchangeable sensor head.

* Listings and approvals under Simplex Time Recorder Co. are the property of Tyco Fire Protection Products.

CO Sensor Base Description

Carbon monoxide (CO) is an odorless, colorless, tasteless gas produced by the incomplete combustion of heating fuels such as wood, coal, heating oil, and natural gas. CO is also a byproduct of many materials experiencing unintentional fire or even incipient fire conditions. Monitoring of CO levels can warn of physically harmful concentrations, however, sensing of CO levels below the harmful level can also provide improved understanding of incipient fire conditions when evaluated in combination with photoelectric fire sensor information from the same location.

Simplex® CO sensor bases combine an electrolytic CO sensing module with a TrueAlarm analog sensor to provide a single multiple sensing assembly using one system address. The CO sensor can be enabled/disabled, used in LED/Switch modes and custom control, and can be made public for communication across a fire alarm Network.

CO sensor operation is similar to other TrueAlarm sensors (photoelectric or heat). It provides current analog values, average analog value, “No Answer” troubles, “Wrong Device” troubles, over threshold, concentration in ppm, and monitors for the presence of the CO sensor. Base mounted address selection allows the address to remain with its location when the sensor is removed for service or type change. Address access is from the front, under the removable sensor. An integral red LED indicates power-on by pulsing, or alarm or trouble when steady on, and also provides test mode status (see page 3). Detailed status is available at the fire alarm control panel.

CO Sensing, Detailed Operation

Toxic Gas Sensing, UL 2075 For CO toxic gas detection, the bases provide toxic gas sensing to the UL 2075 standards. Toxic gas sensing may be selected at the same time as any of the combined CO photo fire detection modes are selected.

Toxic Gas Sensing, OSHA Compliant For OSHA compliant gas sensing, the desired threshold level (above 30 ppm) is selected at the control panel as required for the application, typically for ventilation control. Refer to page 3 for additional OSHA CO monitoring information.

Enhanced Fire Sensing Each sensor provides an analog measurement digitally communicated to the control panel for analysis. At the panel, these analog values are used separately, or combined, to evaluate for conditions indicative of fire, incipient fire, excessive heat, and freeze warning. For fire, the addition of a CO sensor provides two selectable modes of operation: Nuisance Alarm Reduction Mode and Faster Fire Detection. These two modes were developed using the results of extensive testing of actual fires performed under a wide variety of conditions. (Refer to page 4 for additional operation mode options.)

Nuisance Alarm Reduction Mode allows the host control panel to combine photoelectric sensor input and CO sensor level input to reduce false alarms caused by non-fire conditions. Non-fire conditions can be steam from bathroom showers, particles from dusty environments, aerosols from personal care products, tobacco smoke, cooking smoke, or other similar conditions.

CO Sensing, Detailed Operation (Continued)

Nuisance Alarm Reduction Details For applications of anticipated nuisance alarm conditions, photoelectric sensitivity is normally selected for 3.7%/ft smoke obscuration. However, the addition of CO sensing allows the host control panel to apply software verification similar to the timed alarm verification feature often used with conventional smoke detection.

Faster Fire Detection For applications where faster response to incipient or slow building fires is desired and environment appropriate, the Faster Fire Detection mode correlates the outputs of the CO sensor and the photoelectric sensor to provide increased sensitivity. This mode provides earlier detection compared to a standard sensitive photoelectric sensor setting, and also provides more false alarm reduction compared to using a sensitive setting in an area not normally considered appropriate.

Faster Fire Detection Details TrueAlarm photoelectric sensors can be selected to be as sensitive as 0.2%/ft obscuration for applications evaluated as appropriate to that level. However, if the environment is not suitable for that sensitivity level, the Faster Fire Detection mode allows the photoelectric sensor to be selected as a “standard” 2.5%/ft obscuration, but with the presence of a significant level of CO, the combination of CO and photo sensing input can allow an equivalent sensitivity approaching 0.5%/ft obscuration. The host control panel tracks two photoelectric sensitivities, the one selected for photoelectric operation only (typically 2.5%), and the CO correlation sensitivity that it adjusts depending on the amount of CO present.

Control Panel Operations

Smoke sensor features include: sensitivity monitoring satisfying NFPA 72 sensitivity testing requirements, automatic individual sensor calibration checking to verify sensor integrity, automatic environmental compensation, available multi-stage alarm operation, display of sensitivity directly in percent per foot, monitoring of peak activity per sensor, alarm set point, and time of day or multi-stage alarm selection.

Sensor Alarm and Trouble LED Indications

The sensor base LED pulses to indicate communications with the panel. If a sensor is in alarm, or has a trouble condition, the status is annunciated at the control panel and that base LED will turn on steady. During a system alarm, the panel will control LEDs such that a trouble indication will return to pulsing to help identify the sensors in alarm.

Reported CO Sensor troubles are: Disabled, Almost Expired 12 Months, Almost Expired 6 Months, Expired (End of Life), Short, and Sensor Missing/Failed.

Trouble Details

“Almost Expired” is similar to the “Almost Dirty” trouble for a photoelectric sensor. “Expired” trouble is similar to the “Dirty” trouble for a TrueAlarm photoelectric sensor. CO sensor technology does not support automatic sensitivity testing and drift compensation as is available with a photoelectric sensor. End of useful CO sensor life is based upon a set 10 year operational lifetime (5 years for 4100U panels), tracked by date code built into the CO sensor module electronics. Although the CO sensor will continue to function after the expired trouble is indicated, replacement is required to ensure proper detection accuracy.

Control Panel Operations (Continued)

Panel Test Mode allows functional testing of the CO sensor. A test mode is available in the host control panel. In this mode, the CO sensor, and installed heat or smoke sensor can be easily functionally tested.

Panel Test Mode When in the CO test mode, the internal multiple sensor analysis algorithms are disabled allowing each sensor to be quickly tested either individually or simultaneously, depending on the test equipment used. CO testing can be performed using a Solo Model 332 aerosol dispenser (or equal). (Testing is available through your local authorized Simplex product supplier.) The base LED will display steady ON when individual sensors are activated during test. Refer to the Application Reference section for more information.

OSHA CO monitoring For OSHA compliant gas sensing, control panel software supports custom programming based upon CO concentration levels. For example, turn on ventilation if the CO level is above X ppm and then turn off ventilation when the level drops below Y ppm (or select either value as a range if desired). This is separate from alarm set points.

Multi-Point Allocation 4007ES, 4010ES, and 4100ES control panels require only one (1) point at the host panel per CO sensor base. Depending on CO sensor base and sensor choice, up to seven (7) points can be made public to a connected Simplex Fire Alarm Network. Each CO sensor base uses a single address with “sub-points” layered underneath (such as 1-1-0, 1-1-1, 1-1-2,1-1-6). For 4100U control panels, the requirement is three (3) points at the host panel per CO sensor base with the 4098-9754 multi-sensor, and two (2) points for the other sensors. Additional multi-point allocation detail is described in reference data sheet S4090-0011.

CO Sensor Base with 520 Hz Power Requirements

Power for the CO sensor base is provided by IDNet communications. No additional wiring is required for upgrading of existing installed TrueAlarm sensor bases. CO sensor sounder bases do require system supplied separate VDC (or NAC) wiring, the same as the standard sounder base.

TrueAlarm CO Service Reports

TrueAlarm CO Service Reports (sample below) contain information on the CO sensors programmed in the panel displaying pertinent data such as current concentration value in ppm, End of Life date, and current state. This report allows determination of which sensors will require attention. (Sample shows 10 year life tracking with a 4007ES/4010ES/4100ES.)

Service Port				Page 1
REPORT 6 : TrueAlarm CO Report		12:34:56am	MON	06-JUN-14

Channel 1 (M1)				
Zone		Current	End of	
Name	CUSTOM LABEL	Value	Life Date	State
M1-1-2	Conference Room 17 CO Toxic Gas	457PPM	30-MAY-24	PRI
M1-2-2	Boiler Room CO Toxic Gas	0PPM	30-MAY-24	NOR
TRUE ALARM CO REPORT COMPLETED				
Press RETURN for next Screen OR CTRL-X to abort				

Accessories

2098-9808, Remote red LED Alarm Indicator mounts on a single gang box to provide status indications where the sensor location may not be readily visible.

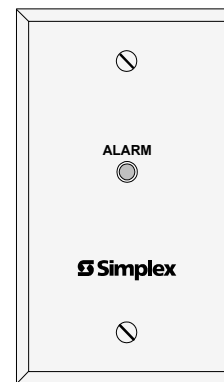

4098-9714 Photoelectric Sensor on CO sensor base

Application Reference

Determine sensor locations after careful consideration of the physical layout and contents of the area to be protected.

For fire alarm applications:

- Refer to NFPA 72, the *National Fire Alarm and Signaling Code*
- On smooth ceilings, smoke sensor spacing of 30 ft (9.1 m) may be used as a guide.

For detailed application information:

- Refer to *4098 Detectors, Sensors, and Bases Application Manual*, Part Number 574-709.

For toxic gas sensor placement and mounting:

- Refer to NFPA 720, *Standard for the Installation of Carbon Monoxide (CO) Warning Equipment in Dwelling Units*
- Per NFPA 720, Section 5.1 (2005 edition):
 - 5.1.1 A carbon monoxide alarm or detector shall be centrally located outside of each separate sleeping area in the immediate vicinity of the bedrooms.
 - 5.1.2 Each alarm or detector shall be located on the wall, ceiling, or other location as specified in the installation instructions that accompany the unit.

Sensors and Accessories Product Selection

TrueAlarm CO Sensor Base

Model	Description
4098-9773	CO Sensor base with 520 Hz Sounder

TrueAlarm Sensors, select one per CO Sensor Base with 520 Hz Sounder

Model	Description	
4098-9714	Photoelectric Smoke Sensor	Refer to selection table below for available operation modes
4098-9754	Multi-Sensor Photoelectric and Heat Sensing	
4098-9733	Heat Sensor	

CO Base Replacement CO Cartridge and Accessories (ordered separately as required)

Model	Description	
4098-9747	CO Replacement Cartridge (CORC). Refer to CORC Replacement Instructions 579-791 for more information.	
Solo 332	Aerosol Dispenser, suitable for larger diameter detectors; can be used for CO or smoke testing	
Solo C3	CO Aerosol Canister (case of 12)	
Model	Description	Mounting Requirements
4098-9863	Adapter Plate required for surface flush 4" square electrical boxes.	Refer to page 6, mounting reference
2098-9808	Remote red LED Alarm Indicator on single gang stainless steel plate. Refer to Installation Instructions 574-707 and Application Manual 574-709 for additional information.	Single gang box, 1-1/2" minimum depth

CO Sensor Base Operation Options with Sensor Choice

Sensor Choice	Mode	Operational Mode Choices* (✓ = operation selected)							
		False Alarm Reduction	Faster Detection	TrueSense Photo/Heat	Photo Fire	Heat Fire**	Utility Temp.	Ion Fire	CO Toxic Gas†
Photoelectric Smoke Sensor 4098-9714	1	✓	—	—	—	—	—	—	option
	2	—	✓	—	option	—	—	—	option
Photo/Heat Multi-Sensor 4098-9754	3	✓	—	—	—	option	option	—	option
	4	—	✓	—	option	option	option	—	option
	5	—	—	✓	option	option	option	—	option
Heat Sensor 4098-9733	6	—	—	—	—	✓	option	—	option
	7	—	—	—	—	option	✓	—	option

* **NOTE:** Duct detection modes are not applicable and are not available. Refer to the Multi-Point Allocation discussion on page 3 for panel point requirement information.

** Heat Fire Mode is 135° F or 155° F, fixed or rate-of-rise.

† CO Toxic Gas operation is selectable as: Supervisory (which is NOT recommended if communicated off-site), Priority 2 (preferred if communicated off-site), or Utility.

TrueAlarm Analog Sensor Features

Sealed against rear air flow entry Electronics are EMI/RFI shielded Heat sensing:

- Selectable rate compensated, fixed temperature sensing with or without rate-of-rise operation
- Rated spacing distance between sensors:

Fixed Temp. Setting	UL& ULC Spacing	FM Spacing, Either Fixed Temperature Setting
135° F (57.2° C)	60 ft x 60 ft (18.3 m)	20 ft x 20 ft (6.1 m) for fixed temperature only; RTI = Quick
155° F (68° C)	40 ft x 40 ft (12.2 m)	50 ft x 50 ft (15.2 m) for fixed temperature with either rate-of-rise selection; RTI = Ultra Fast

Smoke Sensors:

- Photoelectric technology sensing
- 360° smoke entry for optimum response
- Built-in insect screens

4098-9714 Photoelectric Sensor

TrueAlarm photoelectric sensors use a stable, pulsed infrared LED light source and a silicon photodiode receiver to provide consistent and accurate low power smoke sensing. Seven levels of sensitivity are available for each individual sensor, ranging from 0.2% to 3.7% per foot of smoke obscuration. Sensitivities of 0.2%, 0.5%, and 1% are for special applications in clean areas. Standard sensitivities are 1.5%, 2.0%, 2.5%, 3.0%, and 3.7%. Application type and sensitivity are selected and then monitored at the fire alarm control panel. (For detailed application information about sensitivity selection, refer to Installation Instructions 574-709.)

The sensor head design provides 360° smoke entry for optimum smoke response. Due to its photoelectric operation, air velocity is not normally a factor, except for impact on area smoke flow.

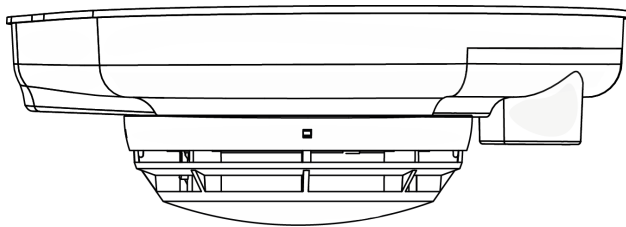

4098-9714 Photoelectric Sensor on CO sensor base

4098-9754 Multi-Sensor

TrueAlarm multi-sensors combine the performance of TrueAlarm photoelectric smoke sensing with TrueAlarm thermal sensing to provide both features in a single assembly. Each sensing element provides data for evaluation at the fire alarm control panel where the following four independent detection modes are evaluated:

- Fixed temperature heat detection
- Rate-of-rise heat detection
- TrueAlarm photoelectric smoke detection
- And TrueSense correlation detection

4098-9754 Multi-Sensor (Continued)

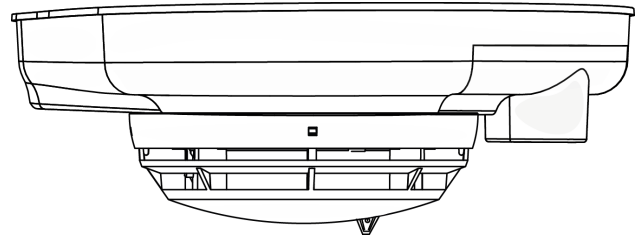

Multi-Sensor on CO Sensor Base

TrueSense analysis correlates thermal activity and smoke activity at a single multi-sensor location using an extensively tested covariance relationship. As a result, TrueSense detection improves response to conditions indicative of faster acting, hot flaming fires when compared to the response of either photoelectric smoke activity or thermal activity alone.

4098-9733 Heat Sensor

TrueAlarm heat sensors are self-restoring and provide rate compensated, fixed temperature sensing, selectable with or without rate-of-rise temperature sensing. Due to its small thermal mass, the sensor accurately and quickly measures the local temperature for analysis at the fire alarm control panel.

Rate-of-rise temperature detection is selectable at the control panel for either 15° F (8.3° C) or 20° F (11.1° C) per minute. Fixed temperature sensing is independent of rate-of-rise sensing and programmable to operate at 135° F (57.2° C) or 155° F (68° C). In a slow developing fire, the temperature may not increase rapidly enough to operate the rate-of-rise feature. However, an alarm will be initiated when the temperature reaches its rated fixed temperature setting.

TrueAlarm heat sensors can be programmed as a utility device to monitor for temperature extremes in the range from 32° F to 155° F (0° C to 68° C). This feature can provide freeze warnings or alert to HVAC system problems.

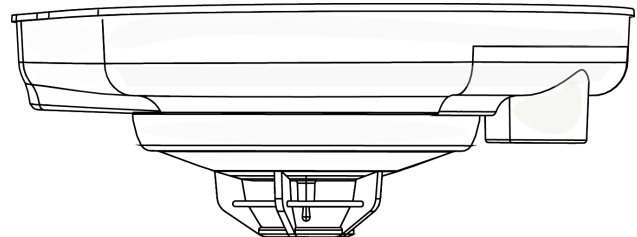

4098-9733 Heat Sensor with CO Sensor Base and CO Sensor

WARNING: In most fires, hazardous levels of smoke and toxic gas can build up before a heat detection device would initiate an alarm. In cases where Life Safety is a factor, the use of smoke detection is highly recommended.

Electrical Box Requirements:

4" octagonal or 4" square, 1-1/2" deep; single gang, 2-1/8" deep

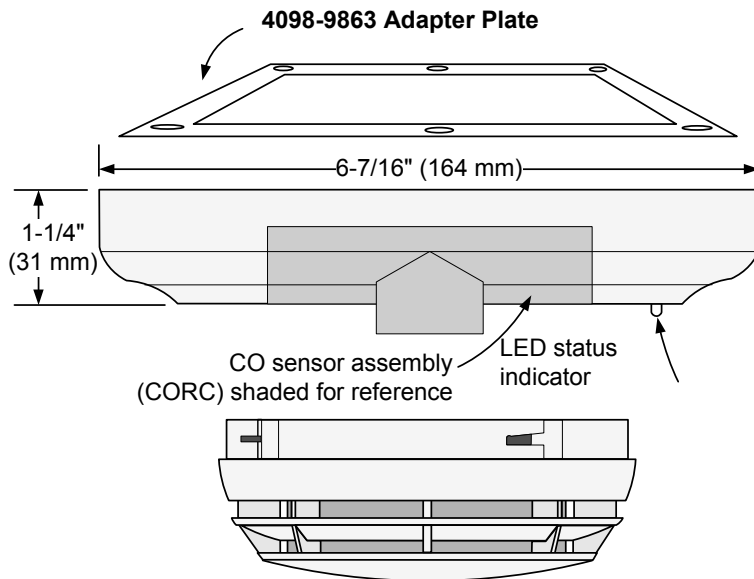
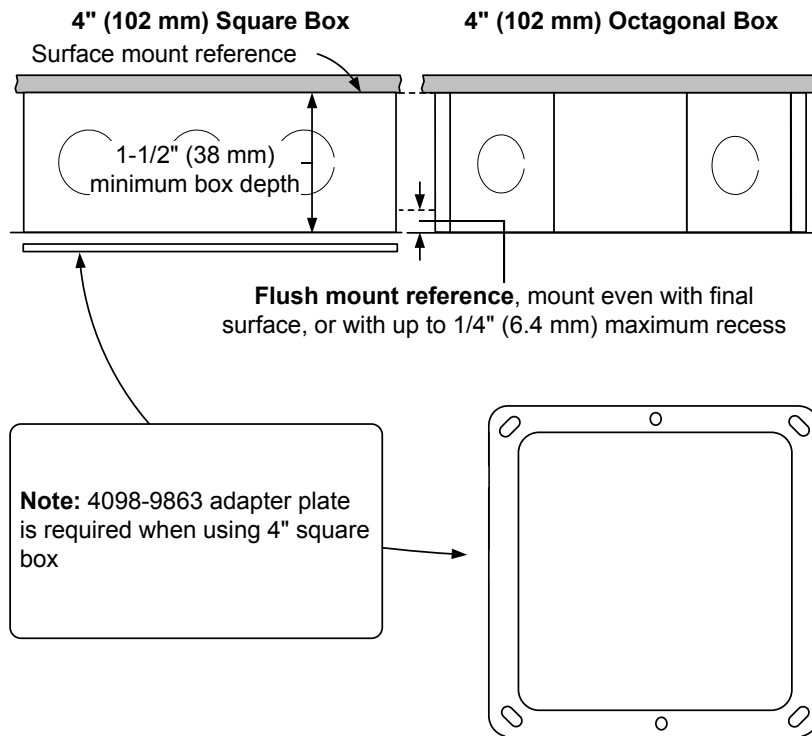

(Photoelectric sensor shown for reference)

NOTES:

1. Sounder Base 4098-9773 requires flush mounting.
2. Review actual wire size, wire count and box type before determining box size.
3. Mounting to flush mounted box also fits single gang handy box, 2-1/8" (51 mm) deep if wiring allows.
4. Refer to Installation Instructions 574-707 for additional information.
5. Refer to CORC Replacement Instructions 579-791 for CO cartridge installation and replacement.
6. The 4098-9773 Sounder base can be mounted at 90 degrees rotation using a single gang box, consult your local SimplexGrinnell contact for further information.

Specifications

General Operating Specifications

Communications and Sensor Supervisory Power	IDNet communications, 1 address per base	
Communications and Sounder Power Connections	Screw terminals for in/out wiring, 18 to 14 AWG (0.82 mm ² to 2.08 mm ²)	
Remote LED Alarm Indicator	Current	1 mA typical supplied from communications, no impact to alarm current
	LED Connections	Color coded wire leads, 18 AWG (0.82 mm ²)
UL Listed Temperature Range	32° F to 100° F (0° C to 38° C)	
Operating Temperature Range	with 4098-9733, 4098-9714 or 4098-9754 32° F to 122° F (0° C to 50° C)	
Humidity Range	10 to 95% RH	
CO Sensor Base Air Velocity Ratings per Sensor	Photoelectric Sensor 4098-9714 and Multi-Sensor 4098-9754 Air velocity = 0-1000 ft/min (0-305 m/min)	
Housing Color	Frost White	
Installation Instructions	574-707	

Sounder Operation

Sounder Voltage	24 VDC nominal, 16 to 32 VDC from NAC		
Alarm Current (Sounder On)	520Hz signal	129 mA @ 16 V, 115 mA @ 18 V	
	Broadband signal	139 mA @ 16 V, 125 mA @ 18 V	
Sounder Output		Minimum sound output @ 10 ft (3 m) per UL Standard 464, <i>Audible Signaling Appliance</i>	Minimum sound output @ 10 ft (3 m) per UL Standard 268, <i>Smoke Detectors for Fire Protective Signaling Systems</i> and CSA 6.19-01
	520 Hz signal	79.5 dBA	85.5 dBA
	Broadband signal	81 dBA	87 dBA
Base Supervision of Sounder Power Input (Selectable)	Supervised	Select for continuous 24 VDC power, loss of power is communicated to panel	
	Unsupervised	Select when connected to NAC for sounder power, NAC provides supervision	
NAC Powered Operation	When in alarm, will sound when NAC is in alarm, allowing synchronized pattern (Temporal or March Time, etc.) controlled by the NAC control		

Reference for CO Monitoring

		Concentration	Alarm Window
Requirements Reference for CSA 6.19-01	Response Time	70 ±5 ppm	60 to 240 minutes
		150 ±5 ppm	10 to 50 minutes
		400 ±10 ppm	4 to 15 minutes
	False Alarm Resistance	30 ±3 ppm	No Alarm for 30 days
		70 ±5 ppm	No Alarm for 60 minutes
UL 2075 Reference, Commercial OSHA Type Operation; Utility Point Mode	With custom control at the fire alarm control panel, Utility Point operations can be performed at lower CO concentration levels Example: Start ventilation after 5 minutes at 25 to 35 ppm and also alarm at a reading higher than that range		

Additional Information Reference

Product	Data Sheet	Product	Data Sheet
Temporal Code 4 Module	S4905-0006	4100ES Control Panels with EPS Power Supplies	S4100-0100
Standard Bases	S4098-0019	4100ES Standard Control Panels	S4100-0031
Isolator Bases	S4098-0025	4100ES Audio Control Reference	S4100-0034
Standard Sounder Base	S4098-0028	4010ES Control Panels	S4010-0004
TrueSense Multi-Sensor	S4098-0024	4007ES Hybrid Control Panels	S4007-0001
TrueAlarm 4098-9772 Sensor Base with 520 Hz Sounder	S4098-0054		

TYCO, SIMPLEX, and the product names listed in this material are marks and/or registered marks. Unauthorized use is strictly prohibited. NFPA 72 and National Fire Alarm and Signaling Code are trademarks of the National Fire Protection Association (NFPA).



Tyco Fire Protection Products • Westminster, MA • 01441-0001 • USA
www.simplex-fire.com

S4098-0053-3 6/2016

© 2016 Tyco Fire Protection Products. All rights reserved. All specifications and other information shown were current as of document revision date and are subject to change without notice.