

SIEMENS

Ingenuity for life

Cerberus[®] PRO Detectors and Peripherals

Photoelectric Smoke Detector Model OP921

Architect & Engineer Specifications

- Compatible with Siemens Model `H'-series devices on the same loop (with Cerberus PRO Modular | FireFinder XLS | FC/FV9-series fire-alarm control panels)
- Compatible with Model 8720 | DPU (device programmer / loop tester)
- Each detector is self-testing:
 - self monitored for sensitivity with UL Listed limits
 - complete diagnostics performed every 10 seconds
- Polarity insensitive via *SureWire™* technology
- Functions with Model DB-11-series mounting bases
- Tri-color detector-status light-emitting diode (LED) with 360 ° view
- Field-selectable application-sensitivity profiles
- Remote sensitivity-measurement capability
- Utilizes advanced, microprocessor-based signal processing
- Extended temperature-and-humidity operating range
- Automatic environment compensation
- Superior electromagnetic interference (EMI) and radio-frequency interference (RFI) immunity
- Restriction of Hazardous Substances (RoHS compliant)
- UL Listed | FM, CSFM Approved
 - UL 268: 'Open Area Smoke Detection'
 - UL 268A (Duct) - 'In-duct housing' use
 - UL 268A (Duct) - 'Direct-in-Duct' use
 - ULC-S531: 'Open Area Smoke Detection'
 - FM 3230 (Duct)
 - CSFM | File: 7272-0067:0258

Product Overview

The Photoelectric Smoke Detector (Model OP921) uses state-of-the-art microcontroller circuitry and surface-mount technology for maximum reliability. Model OP921 incorporates an optical sensor using a light-scattering detection principle. The device utilizes advanced software algorithms to analyze the signals, and provides highly stable and accurate smoke detection.

Model OP921 also uses state-of-the-art microprocessor circuitry with error check; detector self-diagnostics, and supervision programs.

Each detector fits into one (1) wall-or-ceiling footprint, and only occupies one (1) address on the signal-line circuit (SLC)

Model OP921 is a plug-in, two-wire and addressable photoelectric smoke detector. Model OH921 is Underwriters' Laboratories Listed [UL268A Listed for direct in-air duct usage].

Each detector consists of a dust-resistant photoelectric chamber and microprocessor-based electronics with a low-profile plastic housing. Every Model OP921 fire detector is shipped with a protective dust cover.

Operation

Model OP921 is a wide-spectrum, photoelectric smoke detector that incorporates an infrared light-emitting diode (IRLED), as well as a light-sensing photodiode. Under normal conditions, light transmitted by the LED is directed away from the photodiode and scattered through the smoke chamber in a controlled pattern.

The smoke chamber is designed to manage light dissipation and extraneous reflections from dust particles or other non-smoke, airborne contaminants in such a way as to maintain stable, consistent detector operation. When smoke enters the detector chamber, light emitted from the IRLED is scattered by the smoke particles, and is received by the photodiode (see: the computer-graphic images on page 2).



Model OP921
Photoelectric Smoke Detector



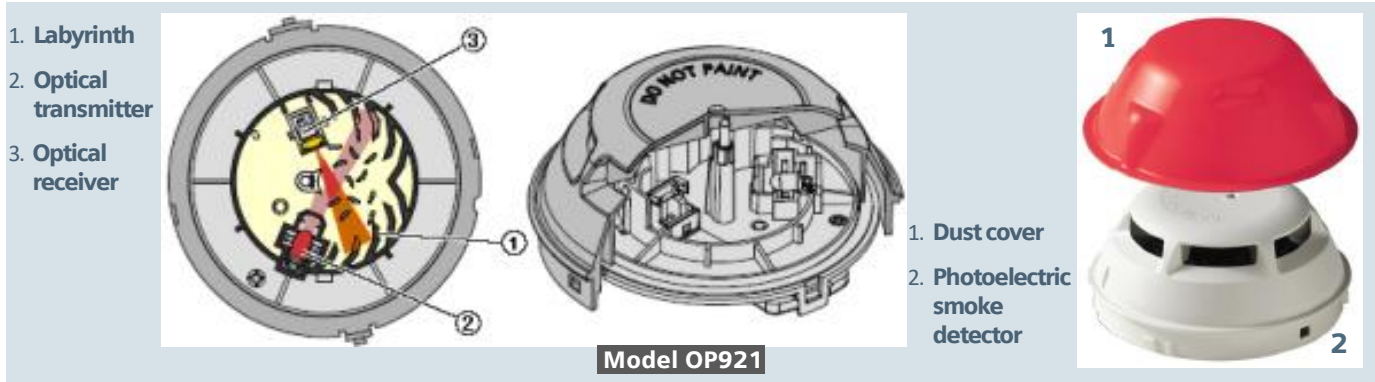

Sensitivity Settings

Application Parameter Sets

Model OP921 provides four (4) pre-programmed sensitivity parameter sets that can be selected by the Siemens fire-alarm control panel in order to match the expected application or environmental conditions:

- Sensitive
- Standard
- Robust
- Air-duct

Sensitive: This application parameter set is practically suitable for areas where few misleading sources of false alarm are present, and is appropriate where priority is given to detecting open fires as soon as possible (e.g. – typically a clean application with controlled environmental conditions).

Standard: This application parameter set, which is ideal for normal office | hotel-lobby-type applications, is the default setting.

Robust: This application parameter set offers improved resistance to false alarms in areas where misleading sources, such as cigarette smoke or exhaust fumes, may cause a nuisance alarm.

Air-Duct: This application parameter set is used when the detector is used a UL268A (DI) compliant, direct in-air duct application without a duct housing.

Model OP921 does not require a field sensitivity test. Model OP921 is UL Listed as a self-testing device and complies with NFPA 72 as a self-monitoring detector and control-panel arrangement. This parameter set is also used when Model OP921 is used in air-duct housings (Models FDBZ492 and FDBZ492-HR).

A quick visual inspection is sufficient to indicate the condition of Model OP921 at any time. If more detailed information is required, a printed report can be provided from the compatible FACP, indicating the status and settings assigned to each individual detector. When Model OP921 moves to 'Alarm' mode, the detector will flash **RED** and continue flashing until the system is reset at the FACP. At that same time, any user-defined, system-alarm functions programmed into the system are activated.

Model OP921 contains a tri-color LED indicator, capable of flashing any one (1) of three (3) distinct colors: **GREEN** | **YELLOW** | **RED**.

During each flash interval, the microprocessor-based detector monitors the following scenarios:

- Smoke sensitivity is within the range indicated on the nameplate label
- Smoke in its sensing chamber
- Internal sensors and electronics are functional

Sensitivity Settings - (continued)

Based on the results of the monitoring, the LED indicator flashes the following:

FLASH COLOR	CONDITION	FLASH INTERVAL [in seconds]
GREEN*:	Normal supervisory operation. Smoke sensitivity is within rated limits.	10
YELLOW:	Detector is in trouble and needs replacement.	4
RED:	'Alarm' condition	1
NO FLASH:	Detector is not powered.	—

* denotes LED can be turned OFF

Please follow the corresponding description of the panel used.

A quick visual inspection is sufficient to indicate the condition of the detector at any time.

If more detailed information is required, a printed report can be provided from the respective Cerberus PRO Modular | FireFinder XLS/V | FC/FV9-series FACP that indicates the status and settings assigned to each individual detector.

Installation

All Model OP921 intelligent, addressable detectors use a surface-mounting base (Model DB-11 or DB-11E), which mounts on a 4-inch (10.2 cm.) octagonal, square or single-gang electrical back box. The base utilizes screw-clamp contacts for electrical connections and self-wiping contacts for increased reliability.

The Model DB-11 detector base can be used with the optional Siemens Model LK-11 detector locking kit, which contains 50 detector locks and an installation tool to prevent unauthorized removal of the detector head. Model DB-11 has aesthetically conducive plugs to cover the outer mounting-screw holes.

Model OP921 may be installed on the same initiating circuit with the Siemens Model 'H'-series detectors [when used with Cerberus PRO Modular | FireFinder XLS/V | FC/FV9-series FACPs] –

- HFP-11, HFPT-11
- Model 'XTRI'-series manual stations
- Model 'HTRI'-series interfaces
- Model 'HMS'-series manual stations
- Model HCP output-control detection devices
- Model 'HZM'-series of addressable, conventional zone modules

Each detector, which is shipped with a protective dust cover, consists of the following:

- Dust-resistant photoelectric chamber
- Solid-state, non-mechanical thermal sensor
- Microprocessor-based electronics with a low-profile plastic housing

All Model OP921 intelligent, addressable detectors are approved for operation with the Underwriters' Laboratories-specified temperature range of 32° to 120° (0° to 49°C).

(See: installation manual P/N – A6V10323928 for further details)

Installation of Model OP921 smoke detectors requires a two-wire circuit. In many retrofit cases, existing wiring may be used. 'T-tapping' is permitted only for Style 4 (Class B) wiring. Model OP921 is polarity insensitive, which can greatly reduce installation and debugging times.

Model OP921 detectors can be applied within the maximum 30-foot center spacing (900 sq. ft. areas) as referenced in NFPA 72. This application guideline is based on ideal conditions – specifically, smooth ceiling surfaces; minimal air movement, and no physical obstructions between potential fire sources and the actual detector. Do not mount detectors in close proximity to ventilation or heating and air conditioning outlets. Exposed joists or beamed ceilings may also affect safe spacing limitations for detectors.

Should questions arise regarding detector placement, observe NFPA 72 guidelines. Good fire-protection-system engineering and common sense dictate how and when fire detectors are installed and used. Contact your local Siemens – Fire Safety distributor or sales office whenever you need assistance applying Model OP921 in unusual applications. Be sure to follow NFPA guidelines and UL Listed / ULC Listed installation instructions – included with every Siemens – Fire Safety detector – and local codes as for all fire protection equipment.

Field-Device Programmer / Test Unit

Model OP921 is compatible with the Siemens field-device programmer / test unit (Model 8720 | DPU), which is a compact, portable and menu-driven accessory for electronically programming and testing these addressable detectors promptly and reliably. For instance, the field technician selects the accessory's program mode, and enters the desired address.

Model DPU eliminates the need for cumbersome, unreliable mechanical programming methods (e.g. – dials and rotary switches), and reduces installation and service costs by electronically programming and testing the detector prior to installation. When set in 'test' mode, Model DPU will perform a series of diagnostic tests without altering the address or other stored data, allowing technicians to determine if the detector is operating properly.

Each field-device programmer / test unit operates on AC power or rechargeable batteries, providing flexibility and convenience in the programming / testing of fire-safety equipment from practically any location. Additionally, with the use of a Model DPU unit, there is no longer a cause for concern with any vibration, corrosion and other deteriorating conditions that can accompany the vitality of a mechanical-addressing mechanism.

Each detector fits into one (1) wall-or-ceiling footprint, and only occupies one (1) address on the signal-line circuit (SLC)

Technical Data		Panel Compatibilities			Details for Ordering		
OPERATING TEMPERATURE:	+32° – +120°F (0° – +49°C)	MODEL OR TYPE	DATA SHEET	PANEL	MODEL OR TYPE	PART NUMBER	PRODUCT
RELATIVE HUMIDITY:	0 – 95% (non-condensing)	XLS	6300	FireFinder® (fire)	OP921	S54320-F4-A2	Photoelectric Smoke Detector
AIR PRESSURE:	No effect	XLSV	6340	FireFinder (fire w/ voice)	Compatible Devices:		
AIR VELOCITY:	0 – 4,000 feet-per-minute (fpm) (0 – 20 meters-per-second)	CERBERUS PRO MODULAR	8300	System Overview	MODEL OR TYPE	PART NUMBER	PRODUCT
INPUT VOLTAGE RANGE:	16VDC – 30VDC	FC901	9813	Cerberus PRO 50-point addressable	DB-11	500-094151	Detector Mounting Base
'ALARM' CURRENT, MAX.:	410µA	FC922	9815	Cerberus PRO 252-pt. addressable (fire)	DB-11E	500-094151E	Detector Base, small
'STANDBY' CURRENT, MAX.:	250µA	FC924		Cerberus PRO 504-pt. addressable (fire)	DB2-HR	S54370-F12-A1	Detector Mounting Base with Relay
MAXIMUM SPACING:	30-ft. centers (900 sq. ft.), per NFPA 72	FV922	9821	Cerberus PRO 252-point addressable (fire w/ Intelligent Voice Communication [IVC])	RL-HC	500-033230	Remote Alarm Indicator: 4" (10.2 cm) octagon.- box mount, red
DETECTOR WEIGHT:	0.317 Lbs. (0.144 kg.)	FV924		504-pt. addressable (fire w/ Intelligent Voice Communication [IVC])	RL-HW	500-033310	Remote Alarm Indicator: single-gang box mount, red
MECHANICAL PROTECTION GUARD:	UL and ULC Listed (with STI Guard Model STI-9604)				FDBZ492	S54319-B22-A1	Addressable Air-Duct Housing
SENSITIVITY RANGE:	1.08 - 2.72% / ft obs. (Nominal 2.0% / ft. obs.)				FDBZ492-HR	S54319-B23-A1	Addressable Air-Duct Detector with Relay
					LK-11	500-695350	Base Locking Kit
See: www.STI-USA.com for further details on ordering Model STI-9604							
In Canada order:							
MODEL OR TYPE	PART NUMBER	PRODUCT					
DB-11C	500-095687	Detector Mounting Base, ULC Listed					

This Page Left Intentionally Blank

NOTICE – The information contained in this data-sheet document is intended only as a summary, and is subject to change without notice. The product(s) described here has/have a specific instruction sheet(s) that cover various technical, limitation and liability information.

Copies of install-type, instruction sheets – as well as the *General Product Warning and Limitations* document, which also contains important data, are provided with the product, and are available from the Manufacturer.

Data contained in the aforesaid type of documentation should be consulted with a fire-safety professional before specifying or using the product.

Any further questions or assistance concerning particular problems that might arise, relative to the proper functioning of the equipment, please contact the Manufacturer.

SIEMENS

Cerberus® PRO

Siemens Industry, Inc.
Smart Infrastructure - Building Products
8 Fernwood Road • Florham Park, NJ 07932
Tel: (973) 593-2600

April 2019
Rev. 8